

# Signature Series

Maximum Resilience Broadcast Audio



## Signature UBBU4

Twin stereo unbalanced to balanced & balanced to unbalanced converter



UBBU4 Front



UBBU4 Rear

## FEATURES

**2 x unbalanced stereo input to balanced stereo output**

**2 x balanced stereo input to unbalanced stereo output**

**Can be used as mono circuits as well as stereo**

**Gain controls to adjust domestic to professional levels and vice versa**

The Signature UBBU4 is a broadcast specification twin stereo unbalanced to balanced, and balanced to unbalanced analogue audio interface that is equally suitable for professional & home studio use.

It is most commonly used for interconnecting domestic type recording / playback devices to broadcast / professional equipment.

Its primary job is to interface domestic type audio outputs (unbalanced) to the balanced audio inputs on broadcast and professional audio equipment while simultaneously connecting balanced outputs from professional equipment to the unbalanced inputs on domestic products.

As well as providing the balancing interface the UBBU4 also provides variable gain/ loss to allow the two connected pieces of equipment to match audio levels.

All the stereo circuits can both work as dual mono. All the inputs are electronically isolated with RF filters to prevent extraneous signals, and fed via multi-turn preset gain controls on the rear panel to their outputs.

The rear panel gain controls are multi-turn presets to allow accurate gain setting and are also recessed to prevent accidental movement.

Power is provided by an internal switch mode power supply with a wide input range. There is also an input for external +/-12V DC power. The +/-12V DC input can be connected to the optional Signature PS1 external DC Master Power Station for situations where a redundant power supply is desirable.

A bright front panel LED indicates that the unit is operational.



**GlenSound**  
Keeps Working

# Signature Series

Maximum Resilience Broadcast Audio



## Signature UBBU4

Twin stereo unbalanced to balanced & balanced to unbalanced converter

### EXAMPLE APPLICATION

#### PC & CD Record / Playback to Broadcast Desk

Interface a domestic PC & CD player to a Broadcast desk

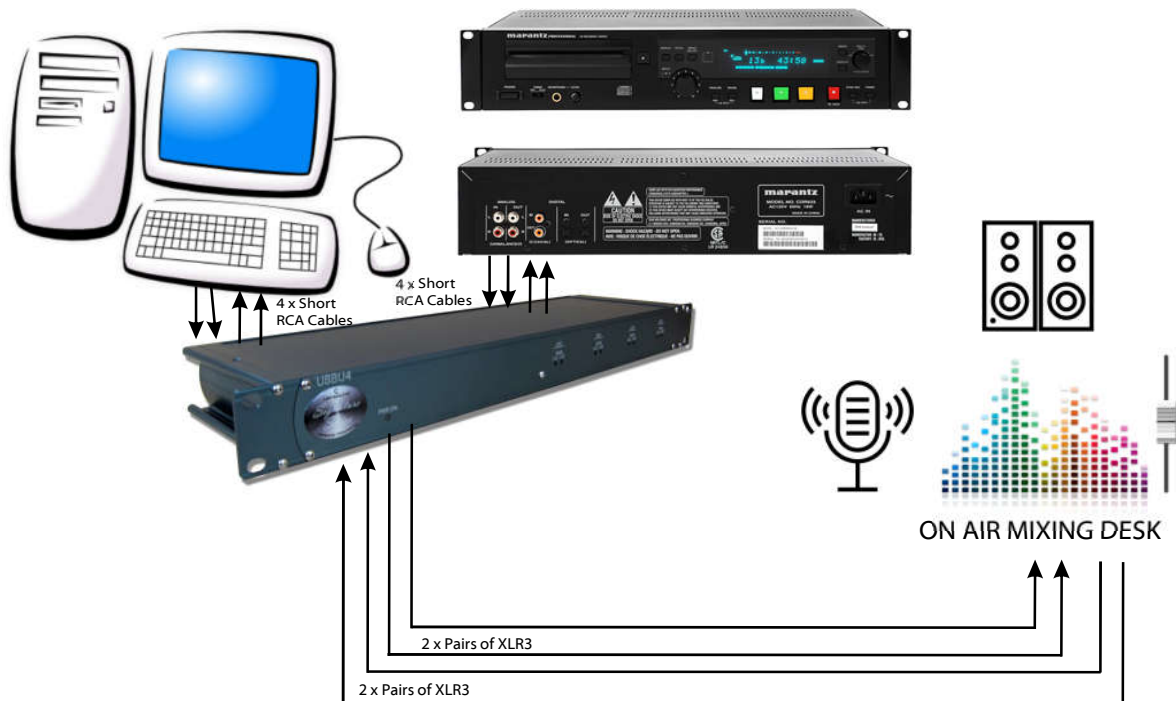

Many radio stations and studios incorporate mid level domestic audio equipment such as CD recorders and PCs with standard sound cards as they provide reasonable value for money in comparison to professional versions.

The output of such devices needs to be correctly interfaced with a professional or broadcast audio desk.

In this example the UBBU4 will be located near the CD recorder & PC as it is prudent to keep the unbalanced audio cables as short as practicable.

The UBBU4 is performing both balance conversion (in and out) and adding gain/ loss to adjust the low domestic input & output level of the CD recorder to the higher levels associated with professional mixing desks.

The inputs & outputs of the UBBU4 on the mixer side, being balanced are more suitable for longer cable runs and therefore the CD recorder, PC and UBBU4 combination can be placed much further away from the mixer than the CD recorder alone could ever be.



**GlenSound**  
Keeps Working

# Signature Series

Maximum Resilience Broadcast Audio



## Signature UBBU4

Twin stereo unbalanced to balanced & balanced to unbalanced converter

### AUDIO BLOCK DIAGRAM

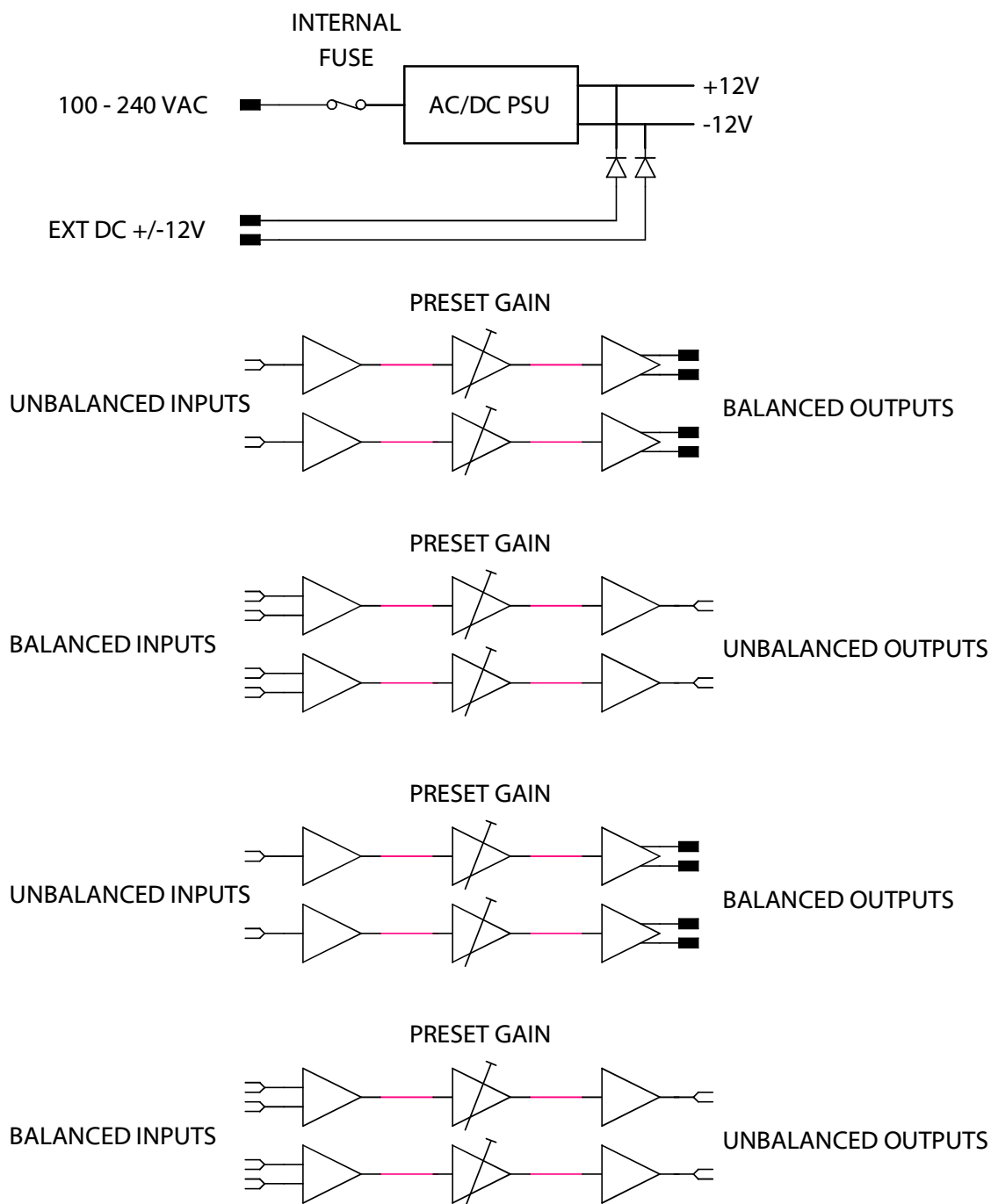



### Signature UBBU4

Twin stereo unbalanced to balanced & balanced to unbalanced converter

## SPECIFICATION

### AUDIO UNBALANCED TO BALANCED

**Frequency Response @ Line Up**

<+/-0.1dB 40Hz to 20kHz

**Gain Range**

-15dB to +15dB on each output

**Line Up Level (with 0dB Gain)**

-12dBu on unbalanced input = 0dBu on balanced output

**Maximum Input Level**

+28dBu

**Maximum Output Level**

+24dBu

**Input Impedance**

>22k Ohms

**Output Impedance**

<50 Ohms

**Distortion**

0.04% THD @ 100Hz, 1kHz & 0.01% @ 10kHz  
Reference to +0dBu output

**Noise**

-98dB @ line up unweighted  
RMS (22Hz to 22kHz) ref +8dBu output

**Crosstalk**

<-90dBu 1kHz to 15kHz @ lineup

### AUDIO BALANCED TO UNBALANCED

**Frequency Response @ Line Up**

<+/-0.1dB 40Hz to 20kHz

**Gain Range**

-18dB to +10dB on each output

**Line Up Level (with 0dB Gain)**

0dBu on balanced input = -12dBu on unbalanced output

**Maximum Input Level**

+28dBu

**Maximum Output Level**

+20dBu

**Input Impedance**

>50k Ohms

**Output Impedance**

<50 Ohms

**Noise**

-103dB @ line up unweighted  
RMS (22Hz to 22kHz) ref -4dBu output

**Crosstalk**

<-90dBu 1kHz to 15kHz @ lineup

### POWER

**Mains Input**

Filtered IEC, 100 to 240VAC  
47 - 63Hz

**AC Consumption**

2.9 Watts

**DC Input**

4 Pin Neutrik XLR plug +/-12V

**Internal Mains Fuse**

20mm 1A Anti Surge

### PHYSICAL

**Size**

445 x 123 x 44mm (LxDxH) no rack ears  
482mm 19" (1RU) with rack ears

**Weight**

1.10kg

**Mechanics**

All aluminium construction, anodized and laser etched

**Shipping Carton**

Rugged export quality cardboard carton  
610 x 420 x 130mm LxDxH

**Shipping Weight**

2.4kg

### INCLUDED

**Mains Lead**

2 Metre Long Mains Lead  
(UK & Europe only)

**Rack Bolts**

4 off Pozi head M6

**Feet**

4 off rubber stick-on feet

**Handbook**

Full A4 handbook available to download  
and linked by QR code on device

**Quick Start Guide**

Available to download

### ENVIRONMENTAL

**Operating Temperature**

0 to +50 °C (32° to 122°F)

**Storage Temperature**

-20 to +70 °C (-4° to 158°F)

**Relative Humidity**

0 to 95% non-condensing

# Signature Series

Maximum Resilience Broadcast Audio



## Signature Series Standard Features

### STANDARD FEATURES

#### 19" Rack Mount Ears



A Signature unit can rack mount in a 1U 19" rack, regardless of the size of the unit. Rack ears are included as standard with every unit.

#### Front Or Rear Mounting



A Signature unit can be rack mounted via the front panel or if it is more convenient, via the rear panel by simply swapping the rack ears over.

#### Side Wings For Flat Surface Fixing



A Signature unit has side wings with mounting holes at the top and bottom, allowing flush fixing from above **OR** underneath.

#### Neutral Colour Scheme To Complement Equipment Areas



#### Rack Screws Included



#### Modern Design



#### Internal Switch Mode AC Power Supply



A Signature unit has an internal switch mode AC power supply, allowing worldwide power connections from 100-240V via an IEC socket.

#### 12V DC Power Connection



All Signature units (except PS1) have a 4 pin XLR  $\pm 12V$  DC socket for connection to the PS1 Power Station. This can act as the primary or backup power source.

#### Quick Find Manual



A Signature unit has a QR code attached. This can be scanned to simply and quickly locate the manual and technical information.

### CONTACT

**Glensound**  
6 Brooks Place, Maidstone  
Kent, UK, ME14 1HE  
Tel: +44 (0)1622 753662  
Web: [www.glensound.com](http://www.glensound.com)  
Email: [sales@glensound.com](mailto:sales@glensound.com)

  
**Glensound**  
Keeps Working